

Repair of Wood Trusses

By Steven E. Fox, P.E.

If you are not familiar with metal plate connected (MPC) wood trusses, take a look around. They are everywhere these days. From humble beginnings 50 years ago, the use of wood trusses has grown at an amazing rate. They are found in nearly all types of residential construction, and are highly competitive in agricultural buildings as well as small commercial projects. You may even have seen them used as part of elaborate concrete form-work for large construction projects. While the growth of the structural building component industry has been excellent over the years, it is not without some growing pains. As the use of trusses has increased throughout the country, so has the incidence of truss damage and modification.

Trusses are generally considered two-dimensional structural elements. They

are typically manufactured from dimensional lumber 1½ inches thick and joined with 16, 18, or 20 gauge metal plates, with integral teeth stamped into the steel. While quite strong in the plane of the truss, they are susceptible to damage if allowed to flex out of plane. This so called “out-of-plane” bending most often occurs during unloading or erection, and can result in breaks and splits in the lumber as well as connector plate damage ranging from tooth pull-out to steel failure (Figures 1 and 2). Residential construction typically incurs less handling damage, due to the smaller truss spans involved. However, the complex nature of the roof and ceiling planes common in today’s homes has resulted in an increase in the modifications required to correct for geometric errors and homeowner’s preferences.

Truss repairs range from the simple addition of dimensional lumber to more involved reinforcements utilizing gussets, beams, prefabricated truss sections, and even steel plates and angles. Unfortunately, there are no code provisions and very limited text book examples to guide engineers at the design stage. The entire repair process relies heavily on the individual engineer’s ability to apply theory, real world judgment, engineering common sense and knowledge of field conditions to develop a practical, economical, and realistic repair for each given situation. Most engineers that design truss repairs learn the skills from another engineer with past experience. While the theory of connections is documented, the art of truss repair remains an elusive concept that can only be developed over years of practice.

The repair design process varies with the complexity of the damage. Typically, for damaged trusses, the original analysis is a valid starting point for determining the axial, shear and bending forces in the damaged area of the truss. Almost all MPC wood trusses are designed on proprietary software from the connector plate manufacturer. This software is dedicated exclusively to truss design, and contains all of the lumber and connector plate properties required to design MPC wood trusses. While it is possible to use independent structural design software, the time involved to match an existing truss design is often extensive due to the lack of specific connector plate values. In cases where there is a change required in the truss shape, the truss must be redesigned with the new profile. Keep in mind, the existing materials must now be capable of withstanding the new forces due to the altered profile. Any new material added should be available locally or provisions should be made through the truss manufacturer to ship less common materials to the job site.

Once the forces have been determined, the focus turns to connections. There are a variety of ways to reconnect members in wood trusses. The two most common are dimensional lumber scabs and gussets of plywood/Oriented Strand Board (O.S.B.). Plywood and O.S.B. are generally interchangeable. The American Plywood Association’s (APA) *Panel Design*



Figure 1: A typical damaged joint. Notice the connector plate teeth have pulled out of the lumber on the right side of the joint, and one web is split along the grain. Also, note the mud on the lumber, a consideration when using adhesives.



Figure 2: Damage to the ends of three trusses resulting when additional trusses were dropped on top of them during delivery.

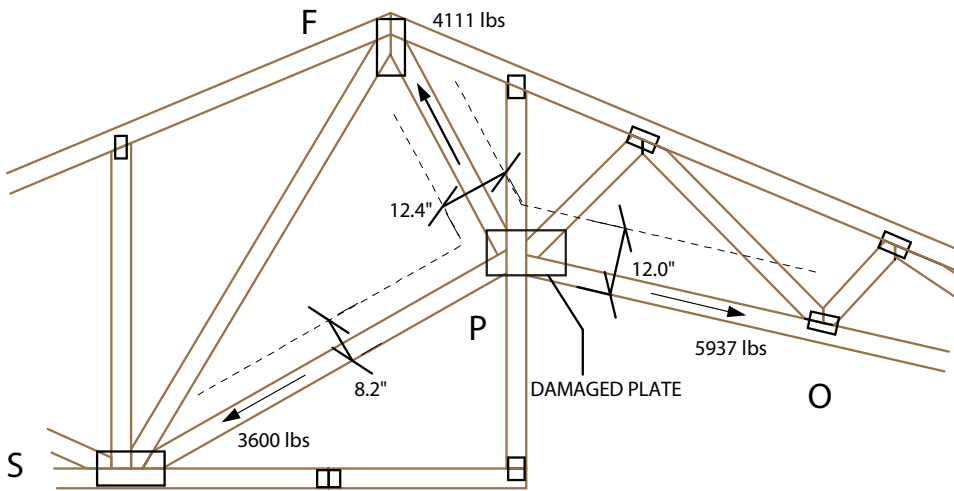

Figure 3: Minimum required gussets widths.

Specification provides design values for both O.S.B. and plywood. Allowable stresses for dimensional lumber are found in American Forest and Paper Association's (AFPA) *National Design Specification (NDS)* and supplement. In certain instances, plated truss sections are manufactured to solve problems where gussets and lumber will not suffice due to strength or geometric considerations. The new truss sections are attached to the face of the existing truss and connected in the appropriate aligning members. If available, a portable hydraulic press may be used to install new members within the plane of the existing truss with connector plates. Repaired trusses utilizing a portable press are often indistinguishable from a new truss directly from the manufacturer. This can be very advantageous in instances where appearance is a concern.

Fastener selection can often prove to be a challenging exercise, due to the wide variety of connectors available. The metal plates used in the manufacture of wood trusses have excellent grip due to the numerous teeth embedded into the lumber. When calculating the quantities of other mechanical fasteners required to repair a damaged plate, it is often surprising to see how much larger the connection areas become. Generally, the nail is the most widely used fastener for wood construction. Nails are commonly referred to by penny-weight. Unfortunately, this designation does not have clearly defined dimensions. There may be four or more different nails commonly referred to by a single penny-weight. For example, a 10 penny (10d) nail could refer to a sinker, common, box, cooler or pneumatic (gun) nail, all of which are slightly different. To eliminate confusion, it is important to specify all nails by length and diameter. Wood screws are another option. Wood screws can

have higher shear values than nails, but often require pilot holes to prevent splitting. The engineer must judge when the extra labor involved to drill pilot holes is worth the effort. Please note that many general purpose screws, such as deck screws and drywall screws, may share a common gauge number with a heavier wood screw, but are not considered structural due to the lower grade steel used in their manufacture and should be avoided for truss repairs. Recently, specialty screws have become available with self-drilling tips, larger diameters, and high yield strengths, resulting in superior performance in relation to standard screws. These screws are manufactured by United Steel Product, Simpson Strong-tie, and Fasten-Master, to name a few. Due to the proprietary nature of these fasteners, it is best to refer to the manufacturer's literature for design values. Finally, machine bolts are generally used where high axial forces are involved. Typically, bolts such as ASTM A307 are specified. Connections in wood trusses rarely benefit from high strength bolts, making them unnecessary. Carriage bolts are not recommended; the lack of a washer and solid bearing on the head of the bolt results in poor performance in relation to machine bolts. Lag screws may be used, but are of limited capacity due to the relatively thin (1½-inch) thickness of the truss members. The lack of penetration limits their lateral strength significantly.

The use of adhesives for truss repairs raises considerable debate among engineers. The quality of some adhesives today allow for bonding wood with greater strength than the wood itself, resulting in much smaller connections. However, the conditions under which many truss repairs are performed can compromise the glue bond. For example, freezing temperatures, surface dirt, and unsupervised

AutoTight®

Tie-Down Systems

System Strength
40% Higher

Stretch 1/8" or less

Shrinkage 1" to 5"

Reliable
Screw Mechanism
Never Releases
Large Bearing Area

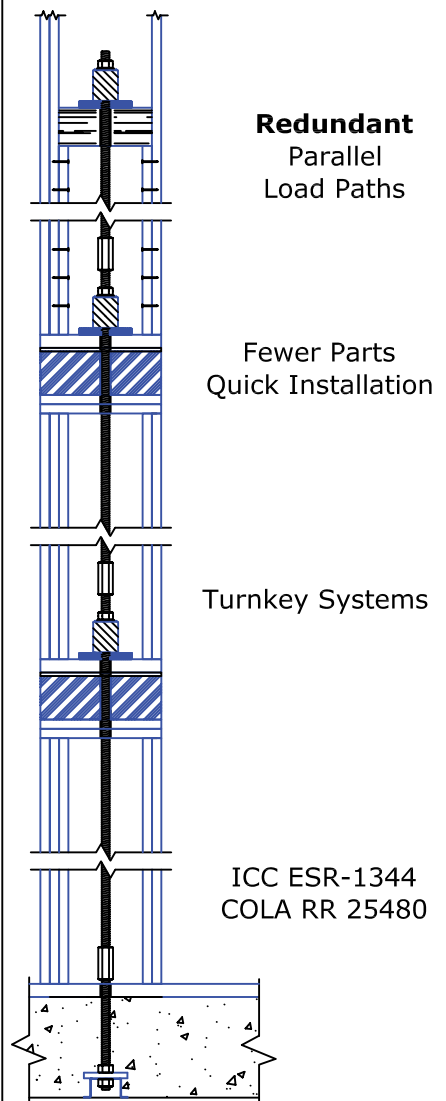

Tie-Downs
Made Easy

360.378.9484

www.comminsmfg.com

ADVERTISEMENT - For Advertiser Information, visit www.STRUCTUREmag.org

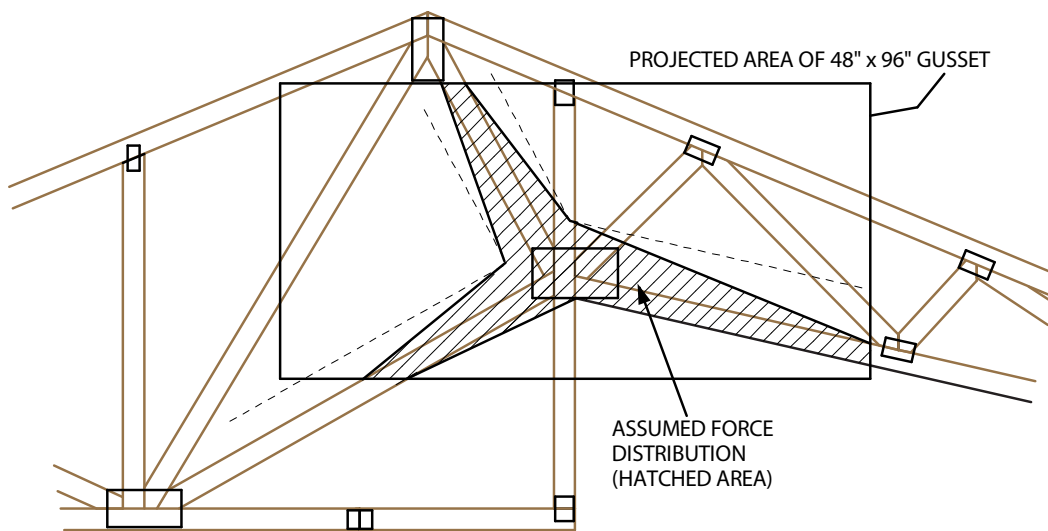

Figure 4: Distribution of tension forces through the gusset.

labor make the capacity of the glued joints difficult, if not impossible, to judge. Mechanical fasteners can be counted to verify conformance with the repair specification. Unfortunately, once the glue is applied and covered, it cannot be seen without destroying the repair. Therefore, adhesive use is best left for controlled environments, such as factories and jobs where the responsible engineer can observe the application of the adhesives. If an adhesive is to be used, the engineer must consider the curing time. In many instances, a truss must be repaired in place. Once a repair is completed, temporary supports are often removed and construction materials are placed on the truss immediately. This practice does not allow proper time for the adhesive to cure. One solution to this problem is to provide mechanical fasteners, designed to support the construction loads, allowing the adhesive the required time to gain sufficient strength before the full design load is applied to the truss. One other school of thought is to specify the adhesive, but not to consider it in the calculations. This is most often done when repairing floor trusses. The mechanical fasteners transfer the forces and the adhesive

provides insurance against squeaks. If the adhesive is omitted, the repair is still valid. If it is used, it only adds strength and stiffness to the repair.

Shear values for gusset connections using nails are given in NDS. A common practice used by many engineers to reduce the connection size is to “clinch” the nails used with gussets, resulting in each nail being placed in double shear. In order to clinch nails, a gusset is placed on each face of a single ply truss. The gusset must be clamped or held in place securely during the nailing procedure. Nails are driven through the front gusset, through the truss, and through the gusset on the back face. The nails must then be bent over flat against the surface of the back gusset. NDS specifies the conditions required to consider clinching. Please bear in mind that clinching must be performed properly. Unfortunately, many repairs specifying clinched nails are performed incorrectly at the jobsite. The first gusset is applied and nails are driven through the gusset and truss and then bent over against the back face of the truss. The second gusset is then applied and nails are driven through all three members and clinched. The small gap

created between the face of the truss and the second gusset due to the first set of clinched nails, while not ideal, is generally not a concern. However, this process results in half the nails in single shear and half in double shear. For example, consider a repair using twenty nails, ten from each face. The first set of ten nails (assuming 50 pounds per nail in single shear), has a capacity of 500 pounds. The second ten nails are in double shear (with 100 pounds per nail) yielding 1000 pounds. The total capacity is 1500 pounds. If all twenty nails were properly clinched, the resulting capacity would

have been 2000 pounds. The result of the improper nailing is a connection that achieves only 75 percent of the design strength. One option is to take into account the 75 percent effective strength and increase the quantity of nails at the design stage, assuring an adequate connection.

To add perspective to the previous discussion, consider the following example. Figure 3 (page 47) depicts a typical vaulted truss with a damaged connector plate at the bottom chord apex. The truss was originally designed on MiTek Industries’ 20/20 engineering software. The forces determined for the original analysis are still valid because there has not been any change to the truss geometry or loading. Members F-P, O-P, and P-S

are the most critical for this connection. These members are all in tension under gravity loading, which requires an investigation of the gussets’ tensile strength. Plywood and O.S.B. have variable tension capacities at different angles relative to the strength axis of the gusset. For axial forces parallel to the strength axis, the allowable tension capacity, Ft, is taken from APA’s *Panel Design Specification* as 467 pounds/inch/pair at 0 degrees and 208 pounds/inch/pair at 90 degrees, assuming 1/2-inch gussets on each face of the truss. Linear interpolation is used to determine the effective tension capacity at various angles. Chord member O-P requires 12.0 inches of gusset based on an angle of 12.9 degrees and a load duration increase of 1.15. The required width for the other critical members is calculated in a similar manner. These widths are illustrated by the dashed lines along the members in Figure 3.

It can be seen from the drawing that the required widths are significantly larger than the widths of the truss members. A rule of thumb for limiting the effective width of gussets is twice the member width. In this case, the members are all 2 x 4’s, allowing 7 inches maximum. The required widths exceed this maximum in all of the critical members. However, due to the nature of this particular joint, it is justifiable to assume that the forces, as they are developed by the nails, will not be fully transferred into the gusset until very near joint P. Figure 4 shows the assumed distribution of forces based upon the minimum required gusset widths. Due to the wide spread of the members pulling the gusset from different angles, the distribution of forces is reasonable for the conditions on this truss. Therefore, the gusset is adequate for the forces present. Figure 5 shows the full gusset in position on the truss. Due to the

ADVERTISEMENT
For Advertiser Information, visit www.STRUCTUREmag.org

Project M US Patent 7,037,030 is Available

- Off-the-Shelf Framing for diverse use-groups.
- Pre-welded / pre-finished members and resilient insulating panels.
- Fastening accessories available mechanical or hinged connections.
- All parts structurally designed and offered in Kit format for swift assemblage.

Keith McLemore, MBA
773-878-3423
raddetect@yahoo.com

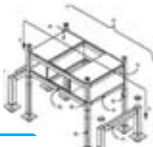

nature of gusset repairs, there is often excess material in some areas as is noticeable on the drawing. It is acceptable to adjust the gusset to a slightly smaller overall size or shape, although the simpler the gusset shape, the easier it is to cut and install. Appearance is generally not an issue, as the repair will not be visible once the ceiling has been installed.

Due to the lack of code provisions governing truss repairs, engineering judgment becomes critical in the determination of what is acceptable. While the design capacities of various materials are available to aid an engineer's calculations, there are times when repairs tend to bring the *art* of engineering to a level almost equal to the *science*. ■

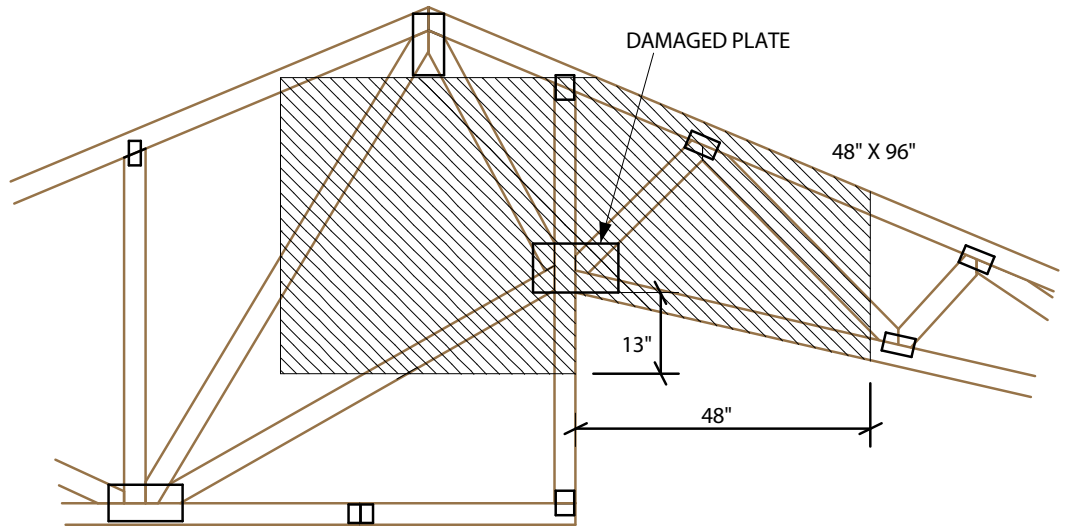

ATTACH 1/2" PLYWOOD OR OSB GUSSET (15/32" APA RATED SHEATHING 32/16 EXP 1) TO EACH FACE OF TRUSS WITH 10d (3" X .131") NAILS DRIVEN THROUGH BOTH SHEETS OF PLYWOOD AND CLINCHED PER THE FOLLOWING NAIL SCHEDULE:
 2 ROWS: SPACED @ 0-4-0 O.C.
 NAILS TO BE DRIVEN FROM BOTH FACES. STAGGER SPACING FROM FRONT TO BACK FACE FOR A NET 0-2-0 O.C. SPACING IN THE MAIN MEMBER. USE A MIN. 0-3-0 MEMBER END DISTANCE.

Figure 5: Finalized repair.

Steven E. Fox, P.E. is currently a Senior Design Engineer for MiTek Industries, Inc. He has specialized in the repair of metal plate connected wood components for the past 18 years. Steven can be reached via email at sfox@mii.com.

ADVERTISEMENT - For Advertiser Information, visit www.STRUCTUREmag.org

We're Shaping Skylines All Over The World



Halcrow Yolles is recognised internationally as one of the premier consulting engineering practices.



Technology and innovation play a crucial role in our ability to provide the right solutions for our clients. By constantly developing the tools and the people who work with them we remain at the forefront of our industry.



Halcrow Yolles combines technical strength, innovative and functional design and superior client service to deliver some of the world's most prestigious buildings. Through our partnerships with celebrated architects we deliver the distinctive, sustainable buildings that are shaping the skylines of some of the world's most exciting and dynamic cities.

A world of opportunity awaits energetic, motivated individuals interested in joining our team.

To find out more about Halcrow Yolles visit our website or email us at halcrowyolles.careers@halcrowyolles.com

halcrowyolles.com

Toronto • New York • Chicago • Las Vegas • Calgary • Cayman Islands • London • Dubai



Halcrow Yolles